

External temperature regulator
TS-1-90
for chimney fans



■ Applications

The temperature regulator is designed for chimney fan control and applied for hot air distribution from chimney to the premises VENTS KAM T1, VENTS KAM Eco T1, VENTS KAM EcoDuo T1.

■ Design and control

The temperature regulator casing is made of metal and equipped with the temperature control knob. The casing is connected with the temperature probe by means of a capillary tube of 1 m length. The temperature level is followed by the temperature

probe which is installed directly inside the fireplace heat-exchanger. The temperature regulator controls the fan operation and switches the chimney fan on or off depending on the set temperature increase or decrease.

■ Mounting

The temperature regulator is mounted in the concealed or external mounting box. The temperature probe is installed inside the fireplace heat-exchanger. The temperature regulator shall be installed away from the source of air heating.

Technical data:

	TS-1-90
Voltage [V/50/60 Hz]	1~ 230
Maximum load current [A]	2,2 A
Maximum fan power [W]	500
Range of controllable temperatures [°C]	0...+90
Overall dimensions of the thermostat casing, [mm]	55 x 56 x 56
Capillary tube length [mm]	1000
Temperature probe	∅ 6,5 x 95 mm
Maximum ambient temperature for the casing [°C]	+80
Maximum temperature for the temperature probe and capillary tube [°C]	+150° C
Protection rating	IP40

■ Applications

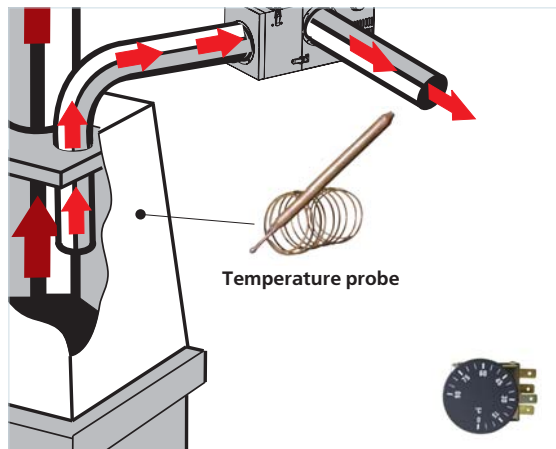

■ Wiring diagrams

Wiring diagram for KAM T1 single-phased motor fan to AC network

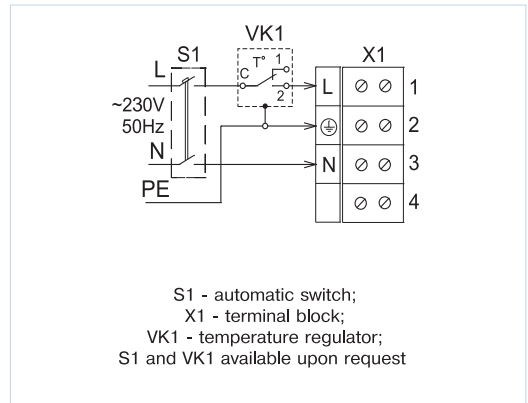

Wiring diagram for KAM EcoDuo T1 single-phased motor fan to AC network.

